

KENWOOD

BASIC G2

STEREO CONTROL AMPLIFIER

SERVICE MANUAL

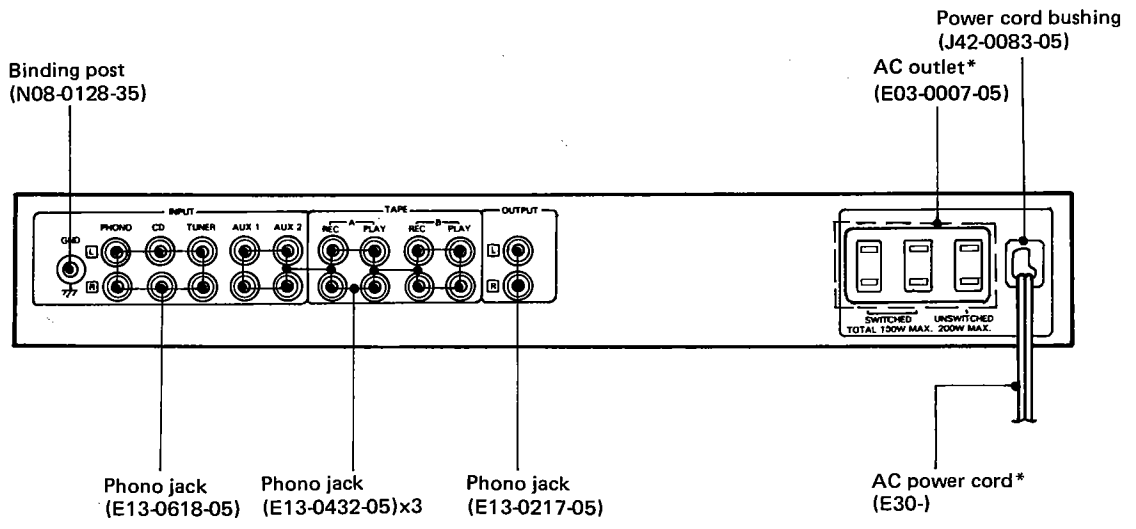
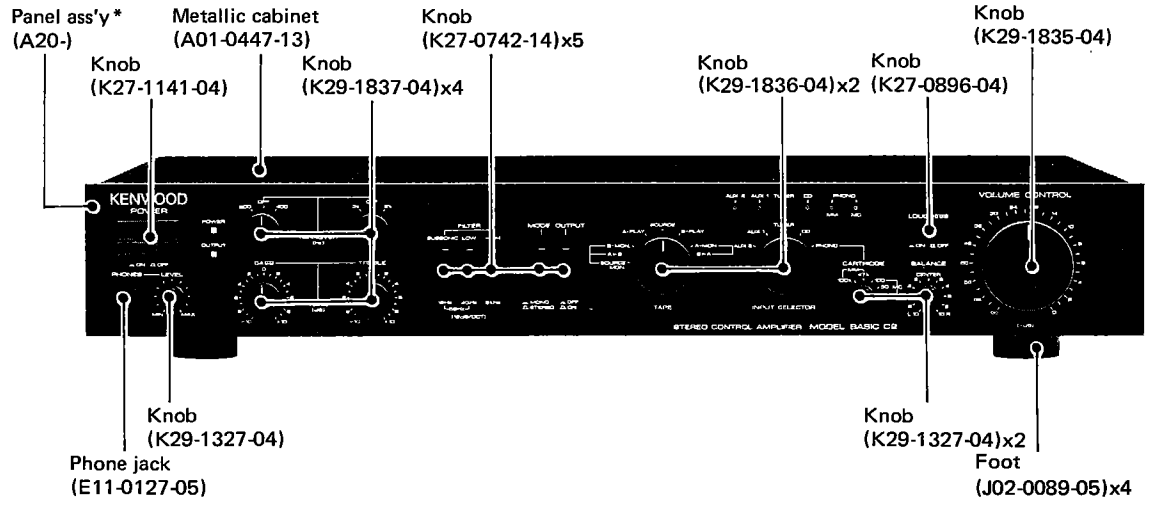

* Refer to Parts list on page 6.

Caution : On EXPLODED VIEW, parts with the exploded numbers larger than 700 are not supplied.

DISASSEMBLY FOR REPAIR

DISASSEMBLY FOR REPAIR

1. Remove the metallic cabinet (①).
2. Remove 3 screws retaining the panel ass'y from the bottom side (②). Remove 2 screws retaining the chassis and the sub panel (③).
3. Remove 4 screws retaining the pcb to the frame (④) and 3 screws at the rear panel (⑤).

Now the pcb can be freed from the chassis with the front panel ass'y and the rear panel attached to the pcb.

4. Lift the front panel ass'y side a little and gradually lift the pcb holding the front and the rear panel (⑥).

Note: Be careful not to let the pcb drop before the rim of the chassis when lifting the pcb up.

5. Stand the pcb as shown in the figure so that components can be replaced (⑦).

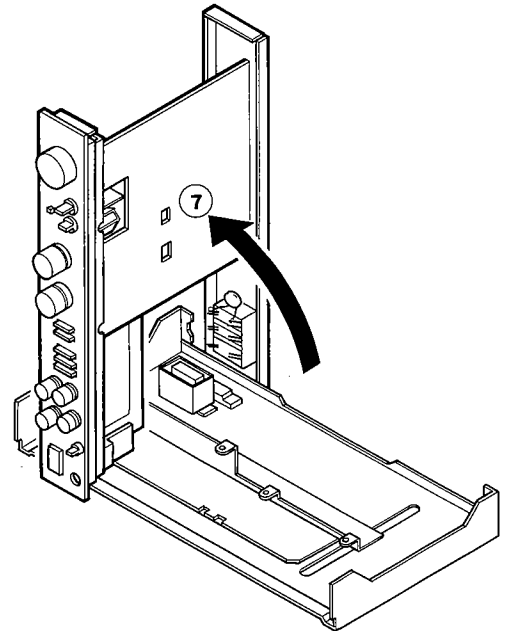
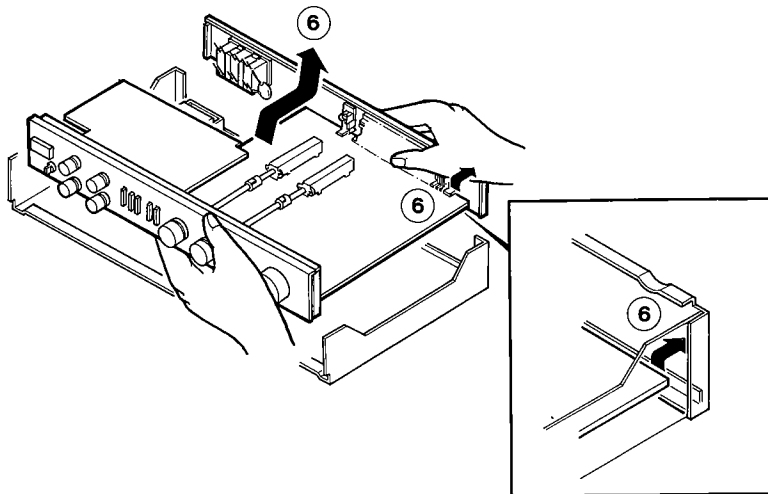
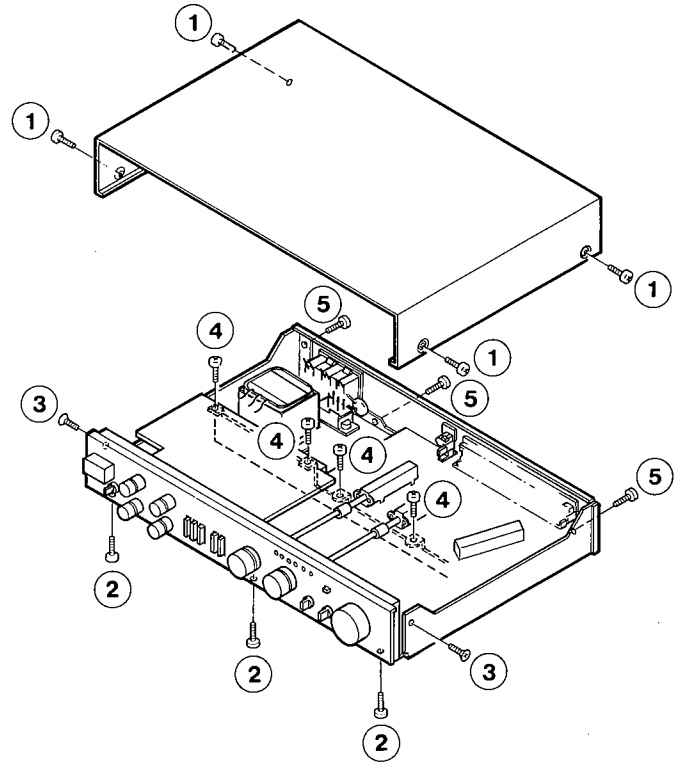

BLOCK DIAGRAM

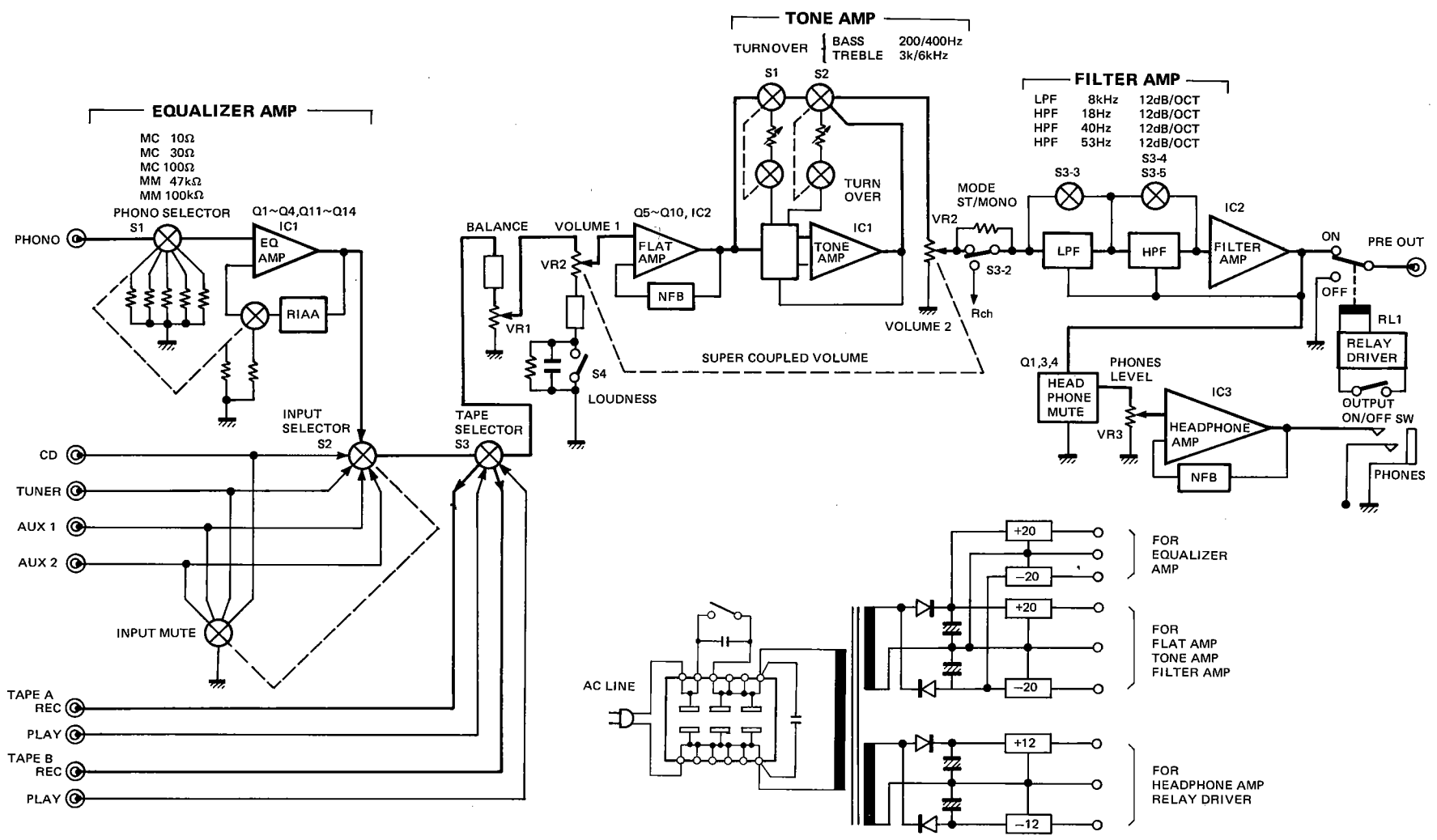

CIRCUIT DESCRIPTION

AUDIO UNIT (X09-2090-10)

Semiconductor	Application and function	Operation, condition and interchangeability
Q1~Q4	EQ. 1st diff.	1st. differential amplifier
Q5, Q6	Flat amp 1st. diff.	1st. differential amplifier
Q7~Q10	Flat amp cathode	Cathode amplifier
Q11~Q14	EQ. cathode	Cathode amplifier
Q21~Q24	± Power supply	AVR for EQ. amplifier
Q25~Q28	± Power supply	AVR for Flat amplifier
Q29, Q30	± Power supply	AVR for Relay drive and LED
Q31~Q34	Relay drive circuit	Output muting
IC1	Amp.	EQ. amplifier
IC2	Amp.	Low noise flat amplifier

CONTROL UNIT (X11-2040-10)

Name	Function	Description
IC1	Tone control	High cut, low cut and output buffer amp.
IC2	Filter amp.	
IC3	Headphone amp.	
Q1~Q3	Muting	Headphone muting

PIN CONNECTION AND DIAGRAM

M5218L (IC3)

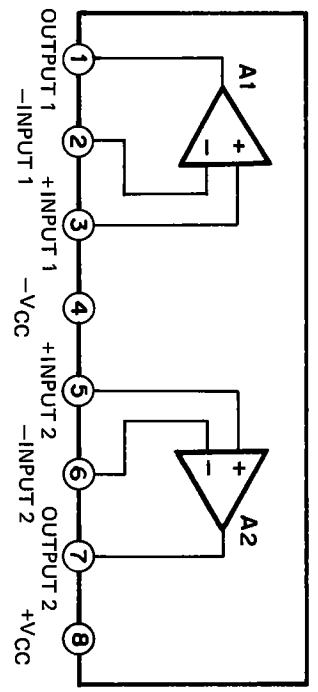

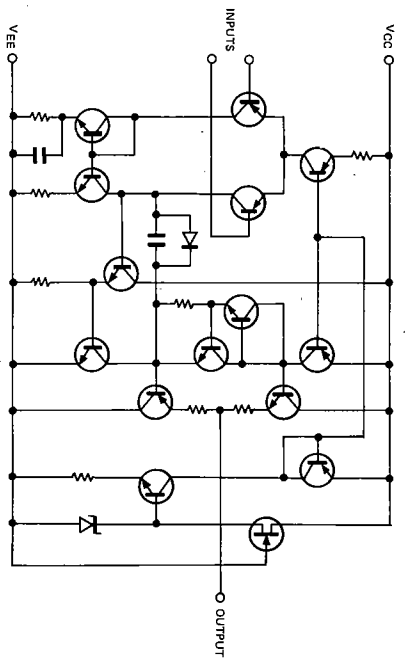
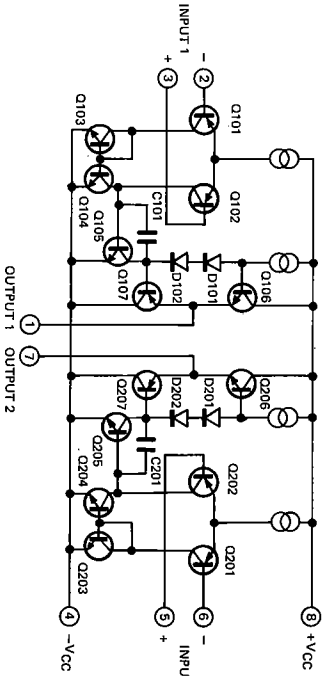
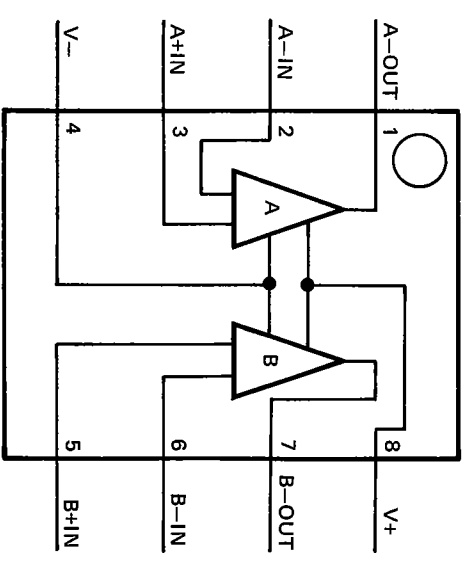

NJM4560D-N (IC1,2)
NJM2041D-D (IC2)



BASIC C2 BASIC C2

PC BOARD

Caution : Some units employed diode E-272 instead of FET  S
(Q23, 24, 27, 28) on X09-2090-10.
If you mount E-272, insert it as shown at right.  E-272

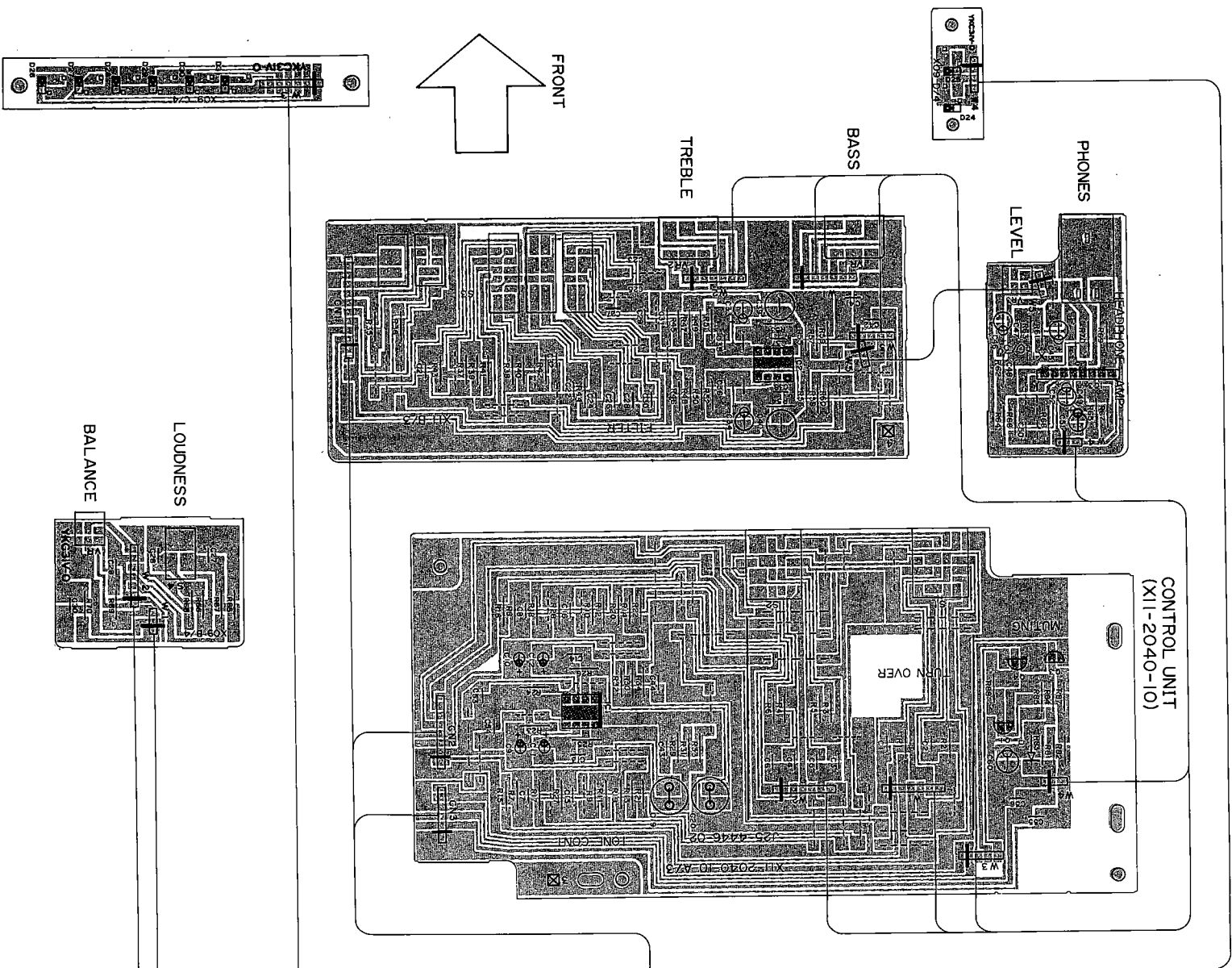

X11-2040-10

IC1,2	IC3
1	0V
2	0V
3	0V
4	-18.5V
5	0V
6	0V
7	0V
8	18.5V

Q1	Q2,3
E	-12.5V
B	-11.9V
C	-12.4V
	0V

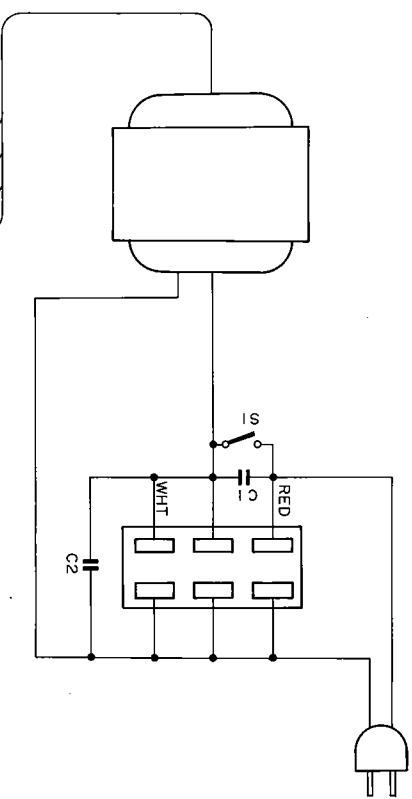

X09-2090-10

IC1	IC2	Q1~4	Q5,6	Q7~10	Q11~14	Q21
1	0V	D	4.1V	E	4.8V	4.1V
2	7.7V	B	0V	B	5.4V	4.7V
3	7.7V	S	0.2V	C	8V	7.1V
4	-18.8V					28V
5	7.7V	Q22	Q25	Q26	Q29	Q30
6	7.7V	E	-18.8V	-18.6V	12.2V	-12.5V
7	0V	B	-14.4V	19.2V	13V	2V
8	18.6V	C	-28V	28V	15.5V	-7V
						2.1V
						9.7V
Q23	Q24	Q27	Q28			Q33
D	25V	-19.4V	25V			E
G	19.4V	-25V	-19.2V			B
S	19.4V	-25V	-19.2V			C
						0.7V

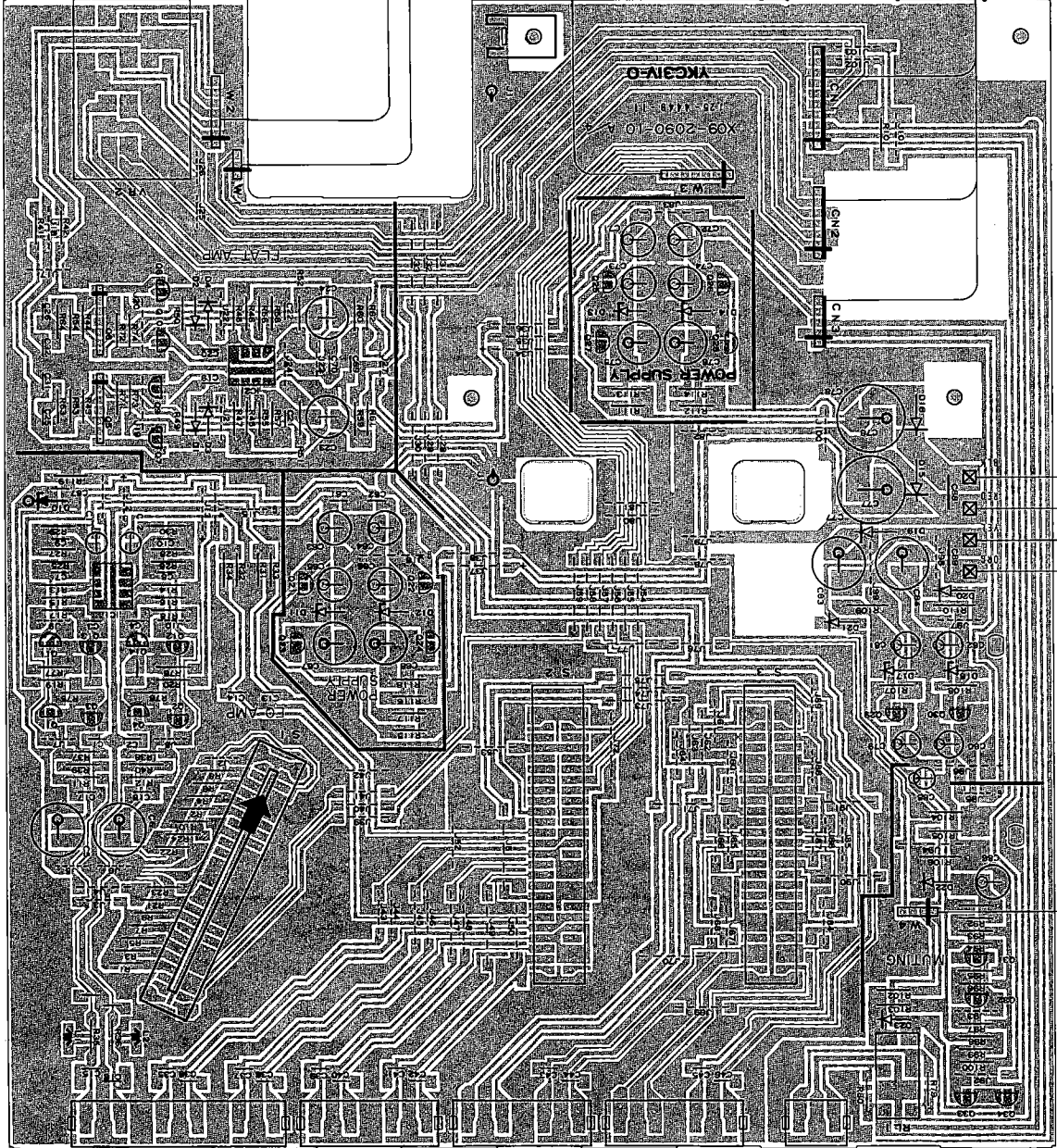

Refer to the schematic diagram for the values of resistors and capacitors.
The PC board drawing is viewed from the side easy to check.

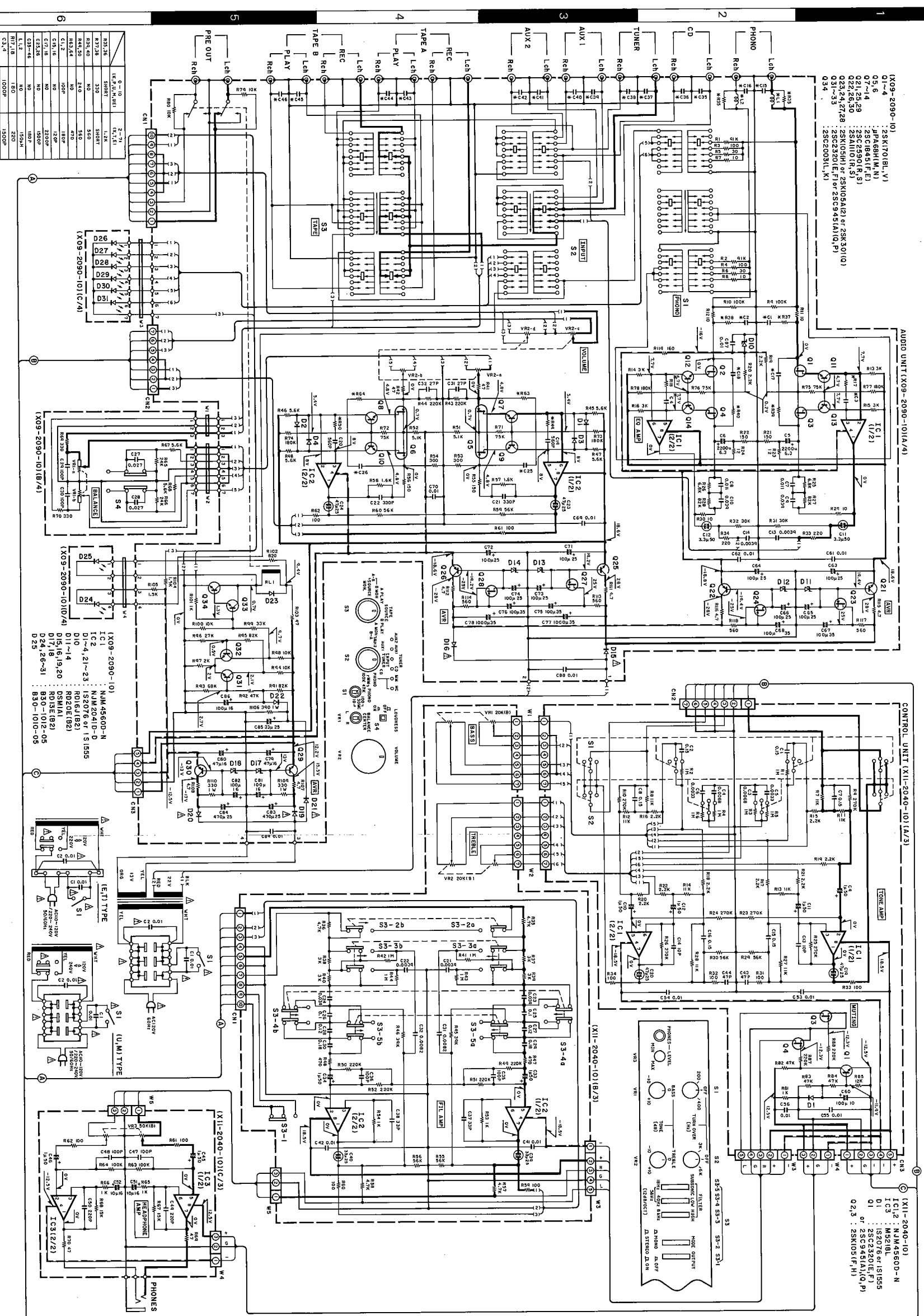

SPECIFICATIONS

Performance

- Input Sensitivity/Impedance/Signal-to-Noise Ratio (HF A Curve)
 - Phono MM: 2.5 mV/30 k, 47 k, 100 k ohms/88 dB
 - CD, AUX, TUNER, TAPE: 200 mV/100 ohms, 200 ohms/70 dB
- Signal-to-Noise Ratio Unweighted at 50 mW (0m)
 - Phono MM & MC: 73 dB
 - CD, AUX, TUNER, TAPE: 79 dB
- Maximum Input Voltage for Phono MC: 200 mV, T.H.D. 0.002%
- Maximum Input Voltage for Phono MM: 15 mV, T.H.D. 0.002%
- Frequency Response
 - Phono MM & MC: 20 Hz - 20 kHz ± 3 dB
 - CD, AUX, TUNER, TAPE: 1 Hz - 350 kHz (-3 dB)
- Tone Control
 - BASS: turnover: 400 Hz, 100 Hz ± 10 dB
 - TREBLE: turnover: 200 Hz, 50 Hz ± 10 dB
 - turnover: 3 kHz, 10 kHz ± 10 dB
 - turnover: 6 kHz, 20 kHz ± 10 dB
- Filter
 - Subsonic: 18 Hz, 12 dB/octave
 - Low: 40 Hz, 12 dB/octave
 - Subsonic + Low: 58 Hz, 12 dB/octave
 - High: 8 kHz, 12 dB/octave
- Transient Response: 1.0 μ s
- Rise Time: 0.001% at 1 V Output
- Total Harmonic Distortion: 0.002%
- CD, AUX, TUNER, TAPE: 20 Hz - 20 kHz
- Phono MM & MC: 20 Hz - 20 kHz
- Output Voltage & Impedance: 150 mV, 220 ohms
- Tape REC: 1,000 mV, 100 ohms
- PRE OUT: 100 Hz, +6 dB
- LA VOLUME: 100 Hz, +9 dB

General

- Power Requirement: 120 V 60 Hz (U.S.A. & Canada models) or 220 V 50 Hz (European model) or 120 V/220 (240) V 50/60 Hz switchable
- Power Consumption: 12 W
- AC Outlet: 1 Unswitched, 2 Switched (except European/Australian countries)
- Dimensions: W 440 mm (17-5/16")
H 78 mm (3-1/16")
D 320 mm (12-19/32")
- Weight (Net): 4.5 kg (9.9 lb)

Kenwood follows a policy of continuous advancements in development. For this reason specifications may be changed without notice.

Kenwood poursuit une politique de progrès constants en ce qui concerne le développement. Pour cette raison, les spécifications sont sujettes à modifications sans préavis. Kenwood s'efforce de perfectionner ses produits sans interruption. Par conséquent, des modifications techniques peuvent être apportées sans préavis.

- DC voltages are as measured with a high impedance voltmeter with no signal input. Values may vary slightly due to variations between individual instruments or/and units.
- Les tensions c.c. doivent être mesurées avec un voltmètre à haute impédance sans signal d'entrée. Les valeurs peuvent varier légèrement du fait des variations inhérentes aux appareils et aux instruments de mesure individuels.
- Die angegebenen Gleichspannungswerte wurden mit einem hochohmigen Voltmeter ohne Eingangssignal gemessen. Dabei schwanken die Messwerte aufgrund von Unterschieden zwischen einzelnen Instrumenten oder Geräten u.U. geringfügig.

CAUTION: For continued safety, replace safety critical components only with manufacturer's recommended parts (refer to parts list). Δ Indicates safety critical components. To reduce the risk of electric shock, leakage-current or resistance measurements shall be carried out (keyposed parts are acceptably insulated from the supply circuit) before the appliance is returned to the customer.

Δ Indicates safety critical component.

- 2SC945
- 2SC1845
- 2SC2003
- 2SC2320
- 2SA1110
- 2SC2590
- 2SK105
- 2SK105A
- 2SK170
- 2SK301
- UPA68H
- NJM2041-D
- NJM4560-D-N
- M521BL

