

MT 1637 SL

SERIE 2

- Maximum lifting height : 15.80 m
 - Capacity : 3700 Kg
- Maximum forward reach : 12.33 m
 - Torque convertor
 - Hydraulic stabilizers
 - Frame levelling

MANISCOOPIC



PERKINS ENGINE 1000 SERIES CONFORMS TO EUROPEAN DIRECTIVE 97/68/EEC



MANITOU

MT 1637 SL TURBO



Lift capacity 3700 Kg
at 500 mm from forks heels.
Tipping load at maximum reach937 Kg
Tear out force with bucket
to ISO 83137000 daN



Lift height :15.80 m
Times : unladen / loaded (in s)
Lifting12/12.5
Lowering8.5/8
Extension 1st and 2nd booms21.8/24.4
Extension 3rd boom (with stabilisers only)10.4/11.5
Retraction 1st and 2nd booms17.7/17.4
Retraction 3rd boom (with stabilisers only)9.7/8.7
Time unladen (in s)
Crowd5.3
Dump8.4



Tyres
440/80-24 T37 158B



Forks (mm)
Length1200
Width x thickness125 X 50
Maximum distance between forks1040
Carriage rotation124°



Multidisc brakes - hydraulically assisted on 4 wheels



PERKINS Engine
Type1004.40 Turbo
Capacity 4 cylindres - 3990 cm³
Power (ISO/TR 14396) :100 HP/74.6 kw
at 2.200 rpm
Maximum torque402.5 Nm at 1400 rpm
Direct Injection
Water Cooling



TransmissionTorque convertor
Electro-hydraulic reversing shift
4 speeds forward and reverse
Maximum travel speed25 Km/h



Hydraulics
Lifting/tilting pump
gear type:260 bar/196 l/mn
Flow divider with priority to steering and brakes



Capacities
Cooling system26.5 l.
Engine oil11 l.
Hydraulic oil175 l.
Transmission oil16 l.
Fuel tank135 l.



Weight unladen (with forks)10860 Kg
Overall width2.43 m
Overall height2.59 m
Turning radius (outside wheels)4.15 m
Overall length5.96 m
Ground clearance0.49 m
Drawbar pull9400 daN

Reach at maximum height : 2.70 m

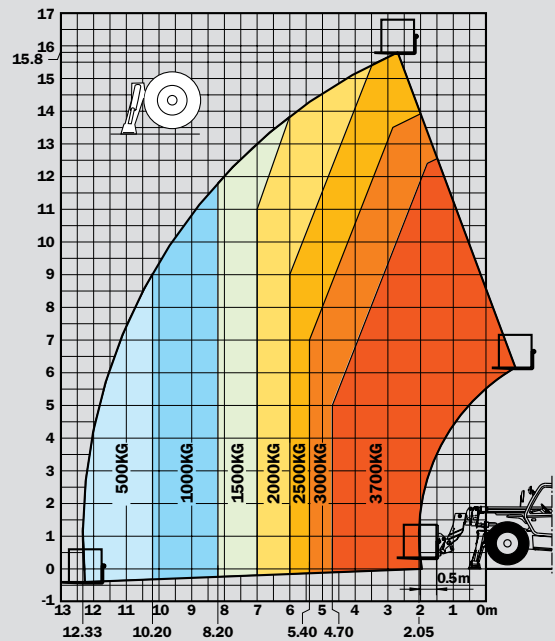

Under
EN 1459
annexe B

A	1200
B	2770
C	2135
C1	2045
D	5955
D1	5865
D2	4435
E	7155
F	1990
F1	1990
G	500
G1	495
G2	500
G3	290
H	4°or7°
H1	4°or7°
I	1050
J	950
K	1040
L	50
N	1880
O	125
P2	45,5°
P3	50°
R	3935
S	8870
T	4665
U1	2590
U2	2770
V	5750
V1	1470
V2	4150
W	2425
W1	3820
W2	1050
W3	2350
Y	12°
Z	112°

mm

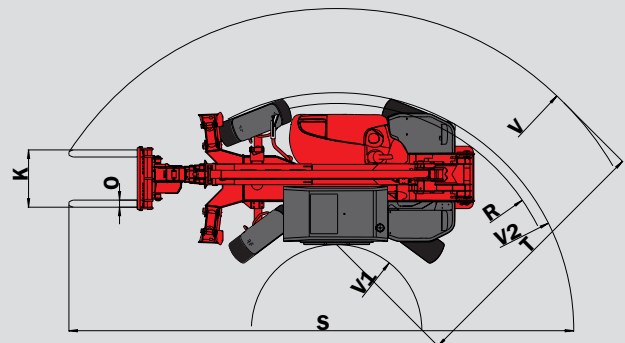
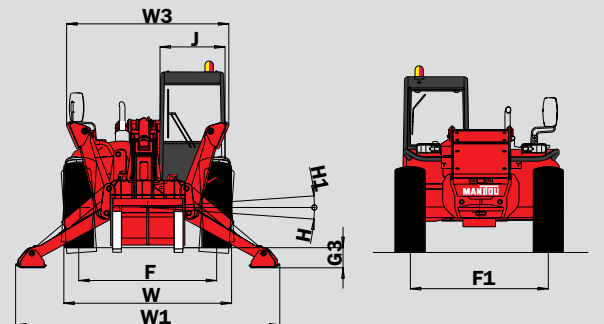
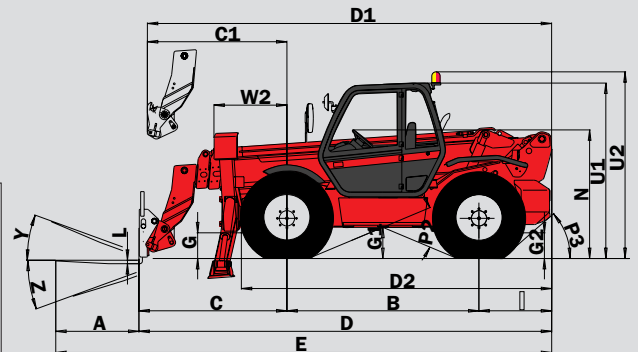

IN ACCORDANCE WITH



This publication in no way constitutes an offer and the company reserves the right to alter specification without prior notice.
The MANITOU models presented in this brochure can be supplied complete with optional equipment attachments
PATENTS FR 93 14367 - EP 0 656 315 US PENDING



MANITOU B.F. S.A.

B.P. 249 - 44158 ANCENIS CEDEX - FRANCE
TEL : 33 2 40 09 10 11
EXPORT DEPARTMENT FAX : 33 2 40 09 10 97
www.manitou.com