

GB	SUMMARY
BEFORE USING THE DISHWASHER	PAGE 13
PROTECTING THE ENVIRONMENT	PAGE 13
PRECAUTIONS AND GENERAL RECOMMENDATIONS	PAGE 13
ENERGY AND WATER SAVING TIPS	PAGE 13
HOW TO FILL THE SALT CONTAINER	PAGE 14
HOW TO FILL THE RINSE AID DISPENSER	PAGE 15
HOW TO FILL THE DETERGENT DISPENSER	PAGE 16
HOW TO USE THE DISHWASHER	PAGE 17
CONNECTIONS	PAGE 18
MAINTENANCE AND CLEANING	PAGE 20
TROUBLESHOOTING GUIDE	PAGE 21
AFTER-SALES SERVICE	PAGE 21

For maximum satisfaction from your dishwasher, carefully read these user instructions and consult the wash programme chart.

BEFORE USING THE DISHWASHER

- After unpacking, make sure the appliance is undamaged and that the door closes correctly. Do not use the appliance if it is damaged. If in doubt, consult your local retailer.
- Keep potentially hazardous packaging (plastic bags etc.) out of the reach of children.
- This appliance is designed for use in the home in compliance with its intended purpose.
- All water and electrical connections must be carried out by a qualified technician in compliance with the manufacturer's instructions (refer to the enclosed installation booklet) and current local safety regulations.

PROTECTING THE ENVIRONMENT

3. Packing

The packing box may be fully recycled as confirmed by the recycling symbol .



4. Appliance

The appliance is built from reusable materials.

If you decide to scrap the dishwasher, it must be disposed of in compliance with local waste disposal laws. Before scrapping, cut off the power cable so that the appliance cannot be connected to the mains.

PRECAUTIONS AND GENERAL RECOMMENDATIONS

Child safety

- Do not allow children to play with the dishwasher.
- Store the detergent, rinse aid and salt in a dry place out of the reach of children.

General recommendations

- Only use detergents, rinse aids and regeneration salts specially recommended for use in domestic dishwashers.
- On completion of the wash programme switch off the dishwasher and turn off the water tap.
- Before cleaning or carrying out maintenance, switch off the appliance, disconnect the mains plug and turn off the water tap.
- If a fault occurs, switch off the appliance and turn off the water tap.
- The open dishwasher door can only support the weight of the loaded rack when pull out. Do not rest objects on the open door or sit or stand on it since the appliance may topple over.

- If necessary, the power cable may be replaced with one the same obtained from our After-Sales Service. The power cable must only be replaced by a qualified technician.

For appliances with water-stop system:

- The water inlet hose and plastic casing contain electrical components. Do not therefore cut the hose or immerse the plastic casing in water. If the hose is damaged switch off the appliance immediately.
- Do not use solvents inside the dishwasher: risk of explosion!
- Load capacity: 12 place settings.

EC Declaration of Conformity

This appliance has been designed, constructed and distributed in compliance with the safety requirements of EC Directives:

- 73/23/EC
- 89/336/EC
- 93/68/EC

ENERGY AND WATER SAVING TIPS

- Do not rinse crockery under running water.
- Always fully load the dishwasher before switching on or set the wash programme to **half load** (if available) if one rack only is loaded.
- If ecological energy sources are available such as solar panel heating, heat pumps or centralised heating systems, the appliance may be connected to the hot water mains up to a maximum temperature of 60°C. Make sure the water inlet hose is of the correct type. Refer to the "Connections" chapter in these user instructions.

HOW TO FILL THE SALT CONTAINER

Check the water hardness level in your area.

Consult your local Water Board or check your last water bill.

- **Set the water hardness by turning the selector (if fitted) inside the door (top left) with a screwdriver. Use the table below to set the dial to the required setting.**

Selector setting	Water hardness	German degrees °dH	French degrees °fH
0	1 soft	0 - 5	0 - 9
1	1 - 2 medium	6 - 10	10 - 18
2	2 medium	11 - 15	19 - 27
3	3 medium-hard	16 - 21	28 - 37
4	4 hard	22 - 28	38 - 50
5	4 very hard	29 - 35	51 - 63
6	4 extremely hard	36 - 60	64 - 107

If the water hardness level falls within category 1 (soft), no salt is required.

- **If the water hardness level exceeds category 1-2 (medium), before using the dishwasher for the first time, fill the salt container and run a wash cycle so that any excess saline solution discharged is immediately removed by the water to prevent corrosion. The pre-rinse cycle is not sufficient for this purpose.**
- **Check the salt level regularly.**
- **Important: Only use regeneration salts recommended for use in domestic dishwashers.**

Do not fill the salt container with detergent as this will cause irreparable damage to the water softener system.

To fill the salt container:

1. Remove the lower rack.
2. Unscrew the cap by turning it counter-clockwise.
3. If the dishwasher is new, fill the salt container to the rim with water.
4. Fill the container to the rim with salt (max. 2 kg) and stir with a spoon handle.
5. Screw the cap back on by turning it clockwise.

Salt level indicator

The dishwasher is equipped with an electric or visual salt level indicator depending on the model installed.

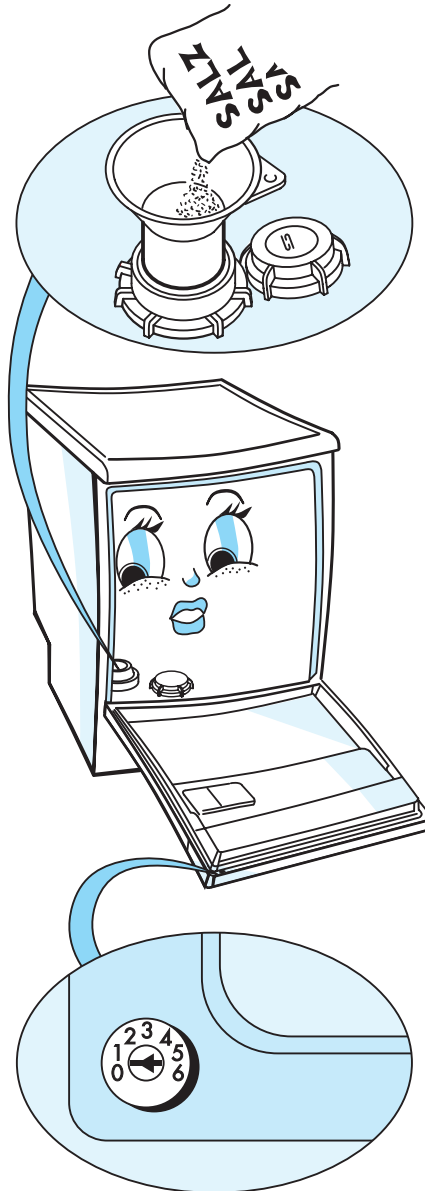

Electric indicator:

The salt level indicator lamp **S** on the control panel illuminates when the salt container is empty.

Visual indicator:

The red float is clearly visible in the cap window when the salt container is full. The red float lowers and is no longer visible when the salt container is empty.

HOW TO FILL THE RINSE AID DISPENSER

The rinse aid facilitates drying and prevents the formation of unsightly spots and streaks on crockery. Before using the dishwasher for the first time, fill the rinse aid dispenser. Thereafter, regularly check the rinse aid level.

Only use rinse aids recommended for use in domestic dishwashers.

1. Unscrew the cap and press button **A** (see drawing). Fill the dispenser with rinse aid up to the dashed line (about 100 ml maximum).
2. **Immediately wipe away any spilt rinse aid to prevent excess suds which may spoil washing results.**
3. Replace the cap.

How to adjust the rinse aid dosage regulator.

(Open the cover and close again following adjustment).

Factory setting: 3.

If you are not satisfied with washing or drying results, change the dial setting with a spoon handle or coin.

If crockery is prone to whitish streaks, reduce the dosage by turning the dial to a lower setting. If instead crockery is wet, increase the dosage by turning the dial to a higher setting.

Rinse aid level indicator (visual or electric indicator depending on the model installed).

Electric indicator:

The indicator lamp  on the control panel illuminates when the rinse aid dispenser is empty.

Visual indicator:

light = empty

dark = full.

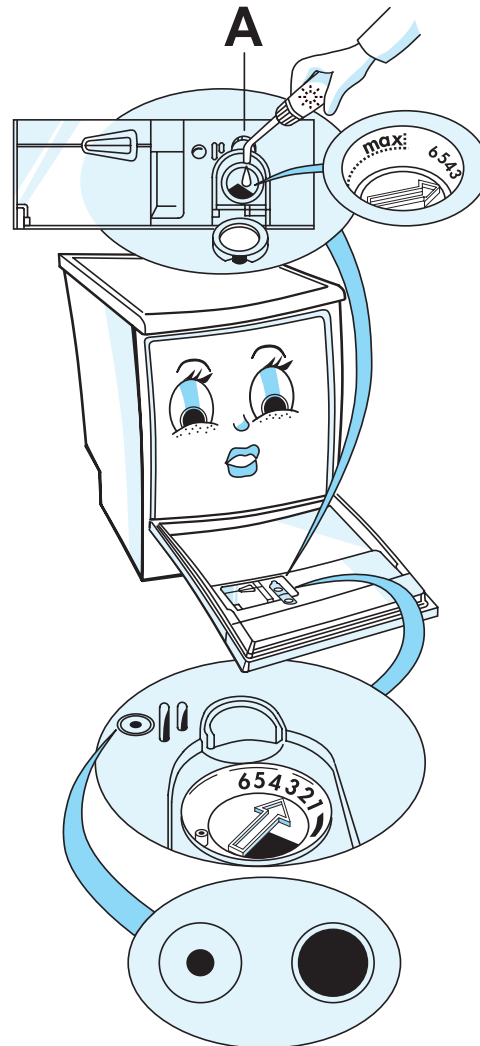

HOW TO FILL THE DETERGENT DISPENSER

Only use detergents recommended for use in domestic dishwashers.

If you use “new generation” enzyme-based detergents, select the Bio programmes which are also suitable for all normal detergents.

If you use detergents in pellet form, follow the manufacturer's directions for use.

Always use the recommended dosage stated on the detergent pack. The use of detergent in excess of the recommended dosage may cause pollution. The recommended dosage varies between different brands.

The figures inside the large compartment serve as a dosage guide.

The The figures are in “ml” or “cm³”.

Only fill the detergent dispenser prior to starting a wash programme.

Normal load:

For programmes with pre-rinse.

(Example: Normal 65°C, refer to the “Wash programme chart”).

First fill the large compartment.
Then fill the small compartment.

1. Pour two thirds of the recommended dosage in the large compartment.
2. Pour the remaining third in the small compartment.

Note: Remember to close the large compartment lid.

Large compartment volume: 45 ml (up to rim).

Small compartment volume: 10 ml (up to rim).

For programmes without pre-rinse:

- Pour the entire recommended dosage in the large compartment. If the recommended dosage on the detergent pack is over 45 ml, pour the remaining detergent in the small compartment.

For programmes with additional selected functions:

“Half load”: load the upper **or** lower rack only.
Use a smaller quantity of detergent.

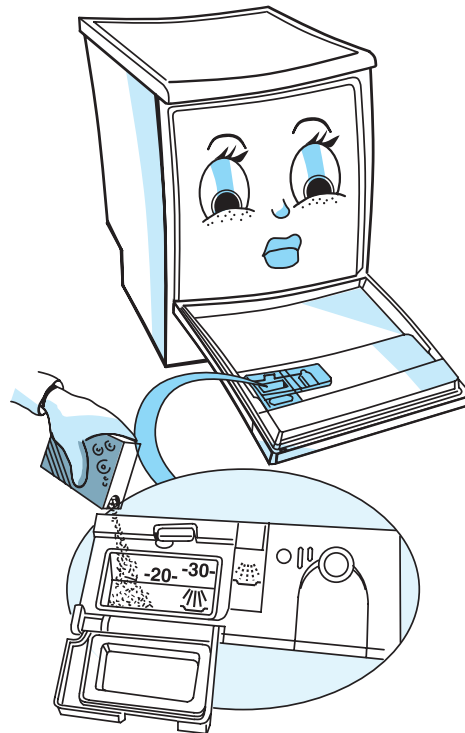

HOW TO USE THE DISHWASHER

Close the dishwasher door and turn on the water tap.

1. Press the **ON/OFF** button to switch on the dishwasher. One of the programme indicator lamps will illuminate.

2. Select the required programme by pressing the **programme** button. The corresponding indicator lamp will illuminate.

If required, select any additional functions.

3. Press the **Start** button to start the selected wash programme. The corresponding indicator lamp will illuminate. Once set, the programmed data cannot be altered by turning the programme selector knob or pressing the buttons.

Note: Once the **Start** button has been pressed, the dishwasher memorises all the programmes selected. The selected programmes are also saved in the event of power failure.

4. To change the programme selected, press the **Start** button for about 5 seconds until the **Start** indicator lamp switches off. Select a new programme using the **programme** button and press the **Start**.

5. The **End** indicator lamp (if fitted) illuminates briefly and the **Start** indicator lamp switches off to indicate the end of the programme.

6. Press the **ON/OFF** button to switch off the dishwasher (only after the **End** indicator lamp has switched on or the **Start** indicator lamp has switched off). All the indicator lamps switch off.

Note: If the dishwasher is switched off during a wash programme, when switched on again the dishwasher resumes the wash cycle from where it was interrupted.

Open the door and unload first the lower rack and then the upper one.

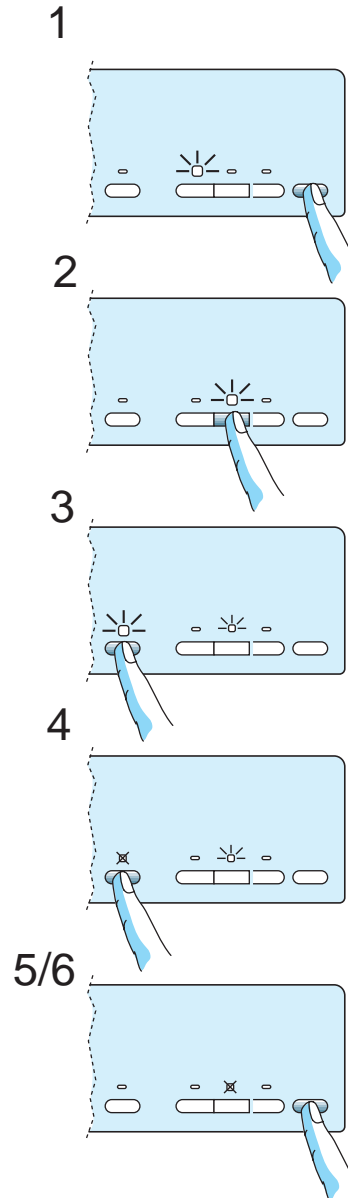

CONNECTIONS

Refer to the separate installation instructions booklet.

Water inlet and drain:

- Strictly follow local Water Board regulations.
- Make sure the inlet and drain hoses are kink-free and are not crushed.
- If the hose length does not suffice, replace with similar hoses obtained from your local dealer or our After-Sales Service.
- The inlet hose must be securely clamped to the water tap to prevent leaks.
- The inlet water temperature varies according to the model installed: inlet hose marked "25°C max.": maximum temperature 25°C. All other models: maximum temperature 60°C.
- When installing the appliance, make sure the drain water discharges correctly and, if necessary, remove the wire gauze from the sink siphon.
- Secure the drain hose with a clamp to the siphon to prevent it from dropping off during operation.
- For appliances with water-stop system only: if the water connections are made correctly, the water-stop system safeguards your home against damage caused by flooding.

Electrical connections:

- Closely adhere to local Electricity Board regulations.
- Voltage information is shown on the rating plate mounted inside the door on the right hand side.
- The appliance must be earthed as prescribed by law.
- Do not use extension leads or multiple adapters etc.
- Before carrying out maintenance, disconnect the mains plug.
- Do not use the dishwasher if it has been damaged in transit. Consult your local retailer or our After-Sales Service.
- The power cable must only be replaced by a qualified technician.

CONNECTIONS

1) ELECTRICAL CONNECTIONS “Warning - this appliance must be earthed”

This appliance is normally supplied with a mains lead having a plug fitted in the factory which has been checked for correct earth continuity.

If the fitted plug is not suitable for your socket outlet, or if the machine's mains lead is not fitted with a plug, you should fit a suitable new, good quality plug by following the instructions in (2) below.

Any unsuitable plug should be cut off and disposed of in order to avoid a possible shock hazard should it be inserted into a socket.

2) CONNECTION TO A REWIRABLE PLUG - to be carried out only by a qualified electrician

The wires in the mains lead are coloured in accordance with the following code:

BLUE - “NEUTRAL” (“N”)

BROWN - “LIVE” (“L”)

GREEN AND YELLOW - “EARTH” (“E”)

To fit a new plug, proceed as follows:

2.1 Polarized Plugs (e.g. 3 pin, 13 amp plug conforming to BS 1363A)

- The GREEN AND YELLOW wire must be connected to the terminal in the plug which is marked with the letter “E” or by the Earth symbol \oplus or coloured yellow or green and yellow.
- The BLUE wire must be connected to the terminal which is marked with the letter “N” or coloured black.
- The BROWN wire must be connected to the terminal which is marked with the letter “L” or coloured red.

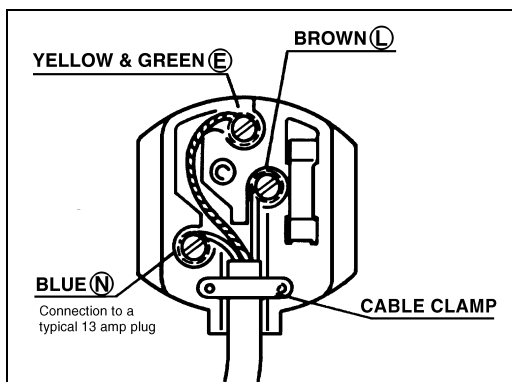

2.2 Non-polarized plugs (e.g. 2 pin with side earth contact)

The wire which is coloured GREEN AND YELLOW must be connected to the earth contact. The other two wires should be connected to the two pins, irrespective of colour.

3) FUSE REPLACEMENT

If the mains lead of this appliance is fitted with a BS 1363A 13 amp fused plug, replace the fuse only with an A.S.T.A. approved type conforming to BS 1362 and proceed as follows:

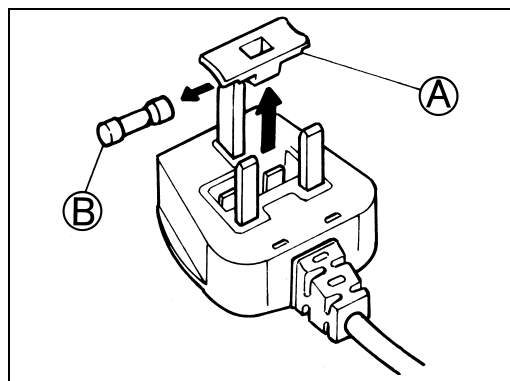

- Remove the fuse cover (A) and the fuse (B).
- Fit the replacement 13 A fuse into the fuse cover.
- Refit both into the plug.

For all other types of plug, the supply socket should be protected by a 16 A fuse or circuit breaker at the distribution board.

MAINTENANCE AND CLEANING

Before cleaning or carrying out maintenance, press the ON/OFF button.

1. Clean the appliance exterior with a neutral detergent. Do not use abrasive detergents.
2. Regularly wipe the door seal and inside of the door with a damp cloth to remove any food residues.

If the spray nozzles become clogged with food residues, clean the spray arms as follows:

Upper spray arm:

- Slacken the fixing nut by turning it counter-clockwise **A** and detach the spray arm by pulling it down **B**.
- Rinse the nozzles.
- Remount the spray arm by aligning it with the rotary mounting and insert it.
- Tighten the fixing nut by turning it clockwise. Make sure the nut is fully tightened (it should click). Make sure the spray arm rotates freely.

Lower spray arm:

- Press the two levers inwards which fix the spray arm **A** and detach by pulling it up **B**.
- Rinse the nozzles.
- Remount the spray arm by aligning it with the rotor pin and insert it.
- Push the spray arm down until it is fixed in place.
- Make sure the two levers are correctly inserted (they should click). Make sure the spray arm rotates freely.

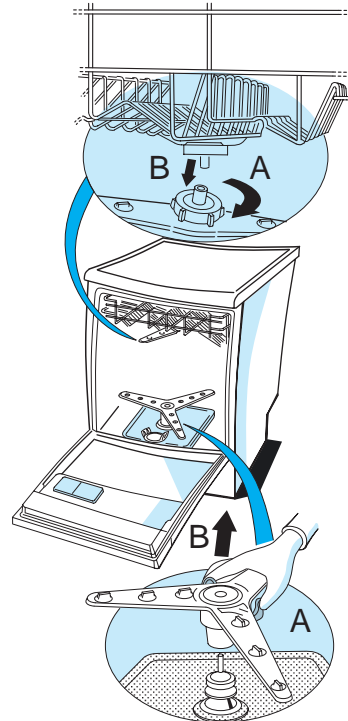

Cleaning the filters

1. Fully unscrew the wide-mesh central filter by turning it counter-clockwise and extract it **A**.
2. Fully unscrew the cylindrical filter and extract it from the wide-mesh central filter **B** (pay due attention to the holes in the bottom of the filter).
3. Remove the fine-mesh filter **C**.
4. Clean all the components.
5. Reassemble:
Insert the cylindrical filter in the wide-mesh central filter. Fit the fine-mesh filter and screw down the filter unit by turning it clockwise. The filter unit must be correctly assembled to ensure good washing results.

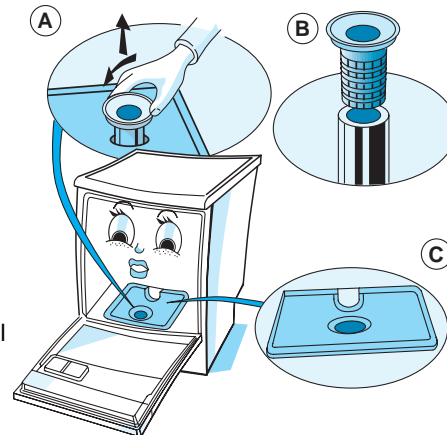

TROUBLESHOOTING GUIDE

If a fault occurs, before contacting our After-Sales Service, make the following checks to try and remedy the problem.

Restart the wash programme to see if the fault repeats.

- Press the **Start** button for about 5 seconds until the **Start** indicator lamp switches off.
- Briefly press the **Start** button.

If the malfunction persists, switch off the appliance and turn off the water tap. Call our After-Sales Service.

The appliance will not switch on:

- Power plug properly inserted in the mains socket?
- Power failure?
- Have you switched the dishwasher on?
- Have you pressed the **Start** button?
- Have you set the delay timer (if fitted)?
- Tap turned on? If not:
 - Turn on the water tap.
 - Make sure the water hose filter is not clogged.

To do this, turn off the water tap, disconnect the water hose, clean the filter, reconnect the water hose to the tap and turn on the tap.
- Filters clogged?
Crockery loaded upside down?
When loading large items in particular, make sure the water circulates and does not collect inside them.
- Door closed properly?
- Fault indicated?
The **Start** indicator lamp or indicator lamp F1...F9 flashes (depending on the model installed), if a fault is detected. F9 flashes (depending on the model installed), if a fault is detected.

Other fault signals depending on the model installed:

The indicator lamp on the control panel flashes  to indicate that the water-stop system has tripped. Switch off the dishwasher, disconnect the mains plug, turn off the water tap and contact our After-Sales Service.

Crockery still dirty after washing:

- Have you selected the correct programme?
- Have you used the correct amount of detergent?
- Filters clogged or incorrectly assembled?
- Spray arms blocked or nozzles clogged?
- Salt container cap screwed down?
- Crockery loaded correctly? (the water jets must spray the entire surface of all items).

Spotted crockery:

- Water hardness duly checked and regulated?
- Salt container empty?
- Insufficient detergent?

Spotted glasses and cutlery:

- Too much rinse aid? (Adjust the rinse aid regulator to a lower setting).

Note:

On some models when the **Start** button is pressed, a pre-rinse cycle is performed prior to the actual wash programme to regenerate the water softener system.

AFTER-SALES SERVICE

Before contacting our After-Sales Service:

1. try to remedy the problem (see "Troubleshooting guide").
2. Switch off the dishwasher and restart the wash programme to see if the fault repeats.

If, after carrying out the above checks the malfunction persists, call our After-Sales Service and specify:

- the nature of the problem;
- the appliance type and model;
- the service number

(the number after the word Service on the adhesive label) located inside the door on the right hand side;

SERVICE 0000 000 00000



- your name, address and telephone number.